

NOTES:

- ① 8W LED LUMINAIRE
- ② RMS-80F SOLAR PANEL SECURED TO ROOF W/ SELF TAPPING SCREWS
- ③ RMS-60F MODULE SECURED WITH INTERNAL FASTENERS
- ④ MOUNTING HOLES ARE NOT PRE-DRILLED HOLES ARE TO BE DRILLED ON SITE TO MATCH SHELTER ROOF
- ⑥ REMOTE SYSTEM CONTROL AND MONITORING WHEN EQUIPPED WITH OPTIONAL ECM CONNECT

\*\*\*OPERATING PROFILE DEPENDENT ON GEOGRAPHIC LOCATION. PLEASE CONTACT URBAN SOLAR FOR ASSISTANCE WITH LIGHTING DESIGN.\*\*\*

TYPICAL INSTALLATION

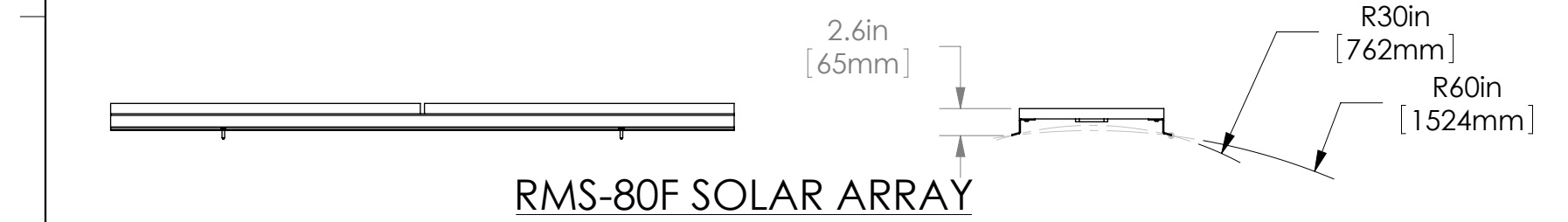
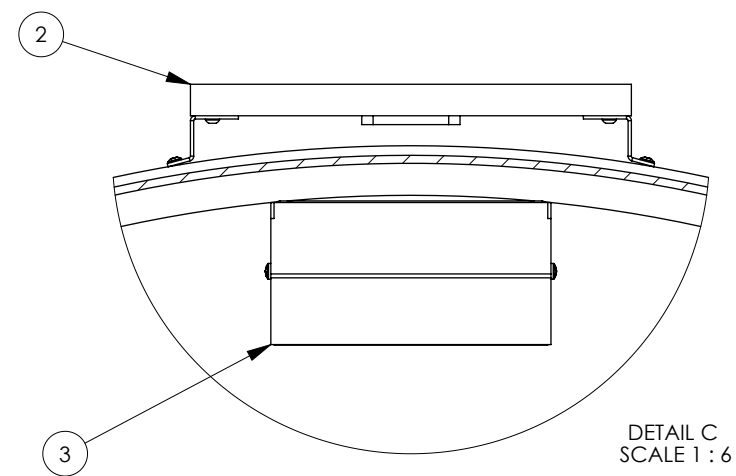
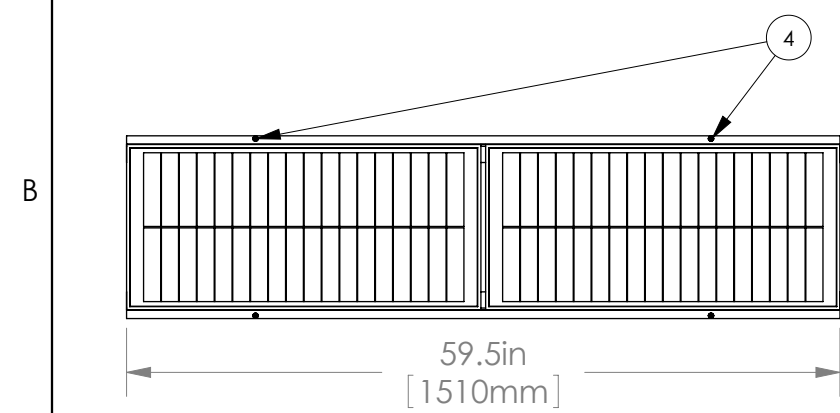

RMS-80F SOLAR ARRAY

RMS-80F SOLAR PANEL



**SPECIFICATIONS:**  
 SOLAR ARRAY (W): 80  
 NOM. SYSTEM VOLTAGE (VDC): 12  
 MAX. BATTERY BANK (Ah): 72  
 BATTERY TYPE: SEALED LEAD ACID (SLA)  
 CONTROLLER: USC ECM C/W REAL TIME CLOCK  
 CHASSIS MATERIAL: ALUMINUM  
 CHASSIS COATING: POWDER COAT - POLYESTER  
 SYSTEM WEIGHT W/ 4 BATTERIES (lbs): 81

PROPRIETARY  
 COPYRIGHT © 2008 BY  
 Urban Solar Corp., Victoria, BC, Canada  
 ALL RIGHTS RESERVED. NO PART OF THIS DOCUMENT MAY  
 BE REPRODUCED STORED IN A RETRIEVAL SYSTEM, OR  
 TRANSMITTED IN ANY FORM, WITHOUT THE WRITTEN  
 PERMISSION OF Urban Solar

DRAWN BY  
 D HANKE  
 DATE  
 18-NOV-2018

TITLE  
**RMS80F - ROOF MOUNTED SHELTER LIGHTING SYSTEM**

DRAWING NO  
**11080**

REVISION  
**A**

PAGE  
**1/1**

